

# Asymmetric Catalysis with Chiral Ferrocene Ligands

LI-XIN DAI,\* TAO TU, SHU-LI YOU,  
WEI-PING DENG, AND XUE-LONG HOU\*

*State Key Laboratory of Organometallic Chemistry, Shanghai Institute of Organic Chemistry, Chinese Academy of Sciences, 354 Fenglin Lu, Shanghai 200032, China*

Received December 13, 2002

## ABSTRACT

Chiral ferrocene ligands have been widely used in asymmetric catalysis. The advantages of using ferrocene as a scaffold for chiral ligands are described, particularly those regarding planar chirality, rigid bulkiness, and ease of derivatization. The role of planar chirality in 1,2- and 1,1'-disubstituted ferrocene systems is discussed. By using a bulky ferrocene fragment, novel ferrocene ligands were designed, and high enantioselectivity and regioselectivity were achieved in the allylic substitution reaction of mono-substituted allyl substrates. Using the tunable electronic properties of a diphosphine-oxazoline ferrocenyl ligand, the regioselectivity of the intermolecular asymmetric Heck reaction was also examined.

## Introduction

Since the discovery of ferrocene in the 1950s,<sup>1</sup> the fascinating structural properties of ferrocene and its derivatives have been the subject of increasing interest in all fields of organometallic chemistry.<sup>2</sup> Indeed, its unique sandwich structure has even been used as a symbol for an international conference on organometallic chemistry. Among a vast number of applications in various areas, the use of

Li-Xin Dai graduated from Zhejiang University in 1947. He entered the Shanghai Institute of Organic Chemistry in 1953. He is now a Professor and Chairman of the Graduate Committee, SIOC. He is an Honorary President of Shanghai Society of Chemistry and Chemical Industry, and the Chairman of the Academic Committee of the State Key Laboratory of Elemento Chemistry in Nankai University. His research interests are the design of chiral ligands and their applications in asymmetric catalysis. He was elected a Member of the Chinese Academy of Sciences in 1993.

Tao Tu was born in Nanchang, China, in 1976. He received his B.S. degree in chemistry from East China Geological Institute in 1998. He is currently pursuing his Ph.D. with Prof. Dai at Shanghai Institute of Organic Chemistry.

Shu-Li You was born in 1975. He obtained his B.S. degree from Nankai University. In 2001, he earned his Ph.D. from Shanghai Institute of Organic Chemistry while working with Profs. Dai and Hou. He is currently doing postdoctor work at Scripps Research Institute.

Wei-Ping Deng was born in 1971. He obtained his B.S. degree from Zhejiang Normal University. In 2000, he earned his Ph.D. from Shanghai Institute of Organic Chemistry while working with Profs. Dai and Hou. He is currently doing postdoctor work at University of Rochester.

Xue-Long Hou graduated from Shanghai First Medical College in 1978. After working there for two years, he entered the Shanghai Institute of Organic Chemistry and obtained his Ph.D. in 1986 under the mentorship of Prof.s Wei Yuan Huang of SIOC and Henry N. C. Wong of the Chinese University of Hong Kong. He was subsequently awarded Alexander von Humboldt research fellowship and completed two years of postdoctoral research with Professor E. Vogel of Cologne University, Germany. He returned to SIOC in 1989 and now is a Professor and Vice Director of the State Key Laboratory of Organometallic Chemistry, SIOC. His research interests are the design of chiral ligands and their application in asymmetric catalysis, asymmetric transformation of aziridines, epoxides, and imines, and the synthesis of theoretically interesting strained molecules.

chiral ferrocenyl compounds as ligands in asymmetric synthesis is most prominent.<sup>2</sup> A wide variety of chiral ferrocenyl ligands are known today. Some of them have played a key role in the development of important catalytic systems in industrial processes. A typical example is the 10 000 tons of herbicide produced per year using a P,P bidentate ferrocene ligand.<sup>3</sup> Many chiral ferrocene ligands are 1,2-disubstituted ferrocenes that usually show both central and a planar chirality. Among the three elements of chirality, planar chirality has received much less attention than central chirality. There have been conflicting reports on the role of planar chirality in asymmetric induction in several reactions. In this Account, we present our recent results regarding the role of planar chirality and control of the enantio- and regioselectivity of several asymmetric reactions with ferrocenyl chiral ligands.

## Desirable Features of Ferrocene for Use as a Scaffold for Chiral Ligands

The following characteristics of ferrocene make it suitable for use as a scaffold for chiral ligands:

1. **Adequate rigidity:** The backbone of a chiral ligand should not be too flexible so as to provide an appropriate chiral environment. Therefore, ring compounds with certain rigidity are usually used as the framework. Ferrocene is a unique ring compound with adequate rigidity.
2. **Easily derivatized:** The cyclopentadienyl ring in ferrocene carries a partial negative charge and is susceptible to electrophilic substitution reactions. Ferrocene reacts  $3 \times 10^6$  times faster than benzene. Thus, it is easy to introduce various donor groups to the ferrocene skeleton.<sup>4</sup>
3. **Planar chirality:** If two functionalities are introduced to the same Cp ring, the ferrocene skeleton offers additional planar chirality.
4. **Steric bulkiness:** The proper steric environment is usually an important factor in governing stereo- and enantioselectivity. The framework of ferrocene is apparently a bulky shield.
5. **Other stereo-electronic properties:** The partial negative charge of the Cp ring gives ferrocene a donor quality. For example, ferrocene amine is a stronger base than aniline, and ferrocenyl carboxylic acid is a weaker acid than benzoic acid. In addition, the central iron atom may, in some cases and to various degrees, interact with the metal introduced in the catalytic system.
6. **Stability:** Ferrocene is thermally stable and tolerant to oxygen and moisture.<sup>2</sup>
7. **Inexpensive and readily available:** Ferrocene costs only US \$ 0.12/ g for 500 g (Aldrich).

On the basis of these characteristics, ferrocene is a scaffold of choice for designing chiral ligands, especially those with planar chirality.

\* Corresponding author.

Scheme 1

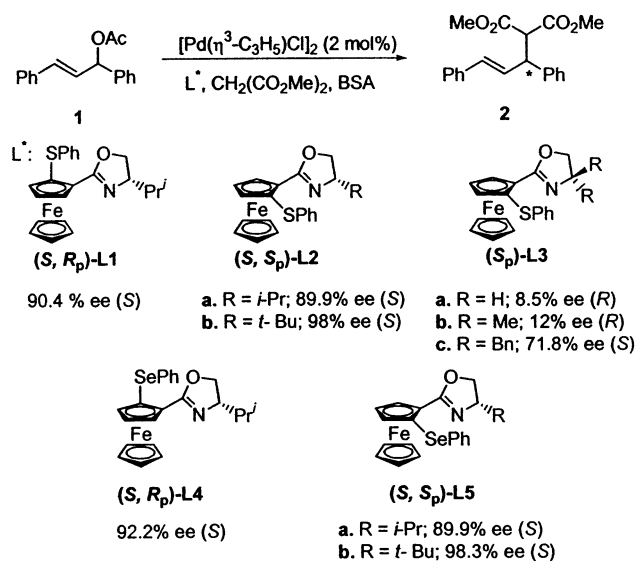

## Role of Planar Chirality in a 1,2-Disubstituted Ferrocene Ligand

1,2-Disubstituted ferrocene compounds are the most studied planar chiral ligands. On the basis of the pioneering work of Ugi in 1970, the diastereoselective *ortho*-metalation reaction of chiral *N,N*-dimethyl- $\alpha$ -ferrocenylethylamine became a convenient route for preparing 1,2-disubstituted ferrocene.<sup>5</sup> This diastereoselective *ortho*-metalation was further elaborated by Sammakia, Richards, Kagan, Snieckus, and many others in several other systems.<sup>6</sup> Thus, a large variety of ferrocene derivatives with planar and central chiralities have been synthesized. However, the effects of planar chirality on the enantiomeric excess and absolute configuration are not so clear. Kumada and co-workers compared the effects of (S,R<sub>p</sub>)-PPFA to those of its diastereomer (R,R<sub>p</sub>)-PPFA and an analogue with only planar chirality (S<sub>p</sub>)-FcPN in a Ni-catalyzed Grignard cross-coupling reaction.<sup>7</sup> They found that planar chirality is a decisive factor for exerting control over the enantiomeric excess and absolute configuration. In 1997, Sammakia reported a similar result in an asymmetric copper-catalyzed conjugated addition of Grignard reagents to enones with chiral ferrocenyl phosphine oxazoline ligands.<sup>8</sup> In some other examples, the effect of planar chirality is not as apparent. On the other hand, Schlögl claimed that central chirality is the decisive element.<sup>9</sup> We also found that central chirality played the decisive role in a hydrogen transfer reaction with a phosphine-oxazoline ferrocenyl ligand.<sup>9b</sup>

We examined the role of the planar chirality of S,N and Se,N bidentate ligands in palladium catalyzed allylic alkylation.<sup>10</sup> When these ligands, (S,R<sub>p</sub>)-L1, (S,Sp)-L2, (S,R<sub>p</sub>)-L4 and (S,Sp)-L5 were used, similar enantioselectivities and the same absolute configuration were obtained regardless of the R<sub>p</sub> or S<sub>p</sub> planar chirality of the ligands (Scheme 1). It seems that the absolute configuration and enantiomeric excess are governed mainly by the central chirality of the oxazoline ring. Furthermore, the P,N-bidentate ligands (S,Sp)-L6 and (S,Sp)-L7 showed similar

Scheme 2

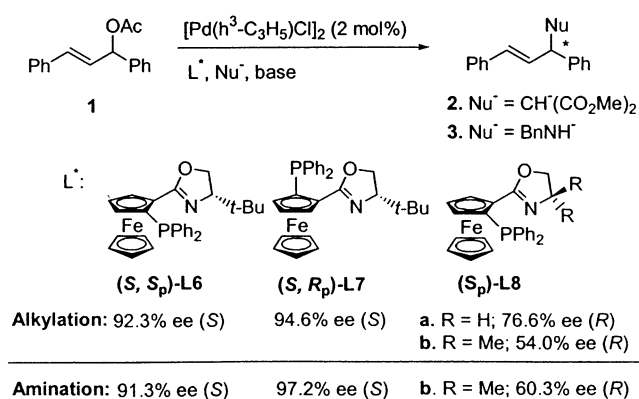

Scheme 3

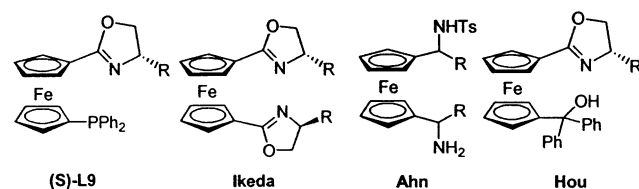

results both in allylic alkylation and allylic amination reactions (Scheme 2).<sup>11</sup> To clarify the effect of planar chirality on the absolute configuration and enantioselectivity of these reactions, ligand (S<sub>p</sub>)-L8, which has only planar chirality, was subjected to those reactions under identical conditions. The ee values were reduced to 54% and 60%, respectively, in these two reactions, but the configurations of the products were changed to *R*. Although the central chirality is the main governing factor, the planar chirality is also important, and (S,Sp)-L7 is the ligand with matched chiralities.

Almost at the same time and using a similar strategy, Bolm reached similar conclusions in the diethylzinc addition of benzaldehyde with 1,2-hydroxy-oxazoliny ferrocene ligand.<sup>12</sup>

Therefore, in 1,2-disubstituted ferrocenyl ligands, the enantioselectivity in the reactions discussed above is mainly determined by the central chirality. The matching of planar and central chiralities is essential for obtaining excellent asymmetric induction and also demonstrates the importance of planar chirality. On the basis of a study of X-ray diffraction and/or solution NMR spectra of the palladium allylic complex of these ligands, there was probably no dramatic change in the conformation in these systems, when the planar chirality was altered.<sup>11</sup>

## Role of Planar Chirality in 1,1'-Disubstituted Ferrocene Ligands

In the above section, the two coordination groups are situated on the same Cp ring. What about when they are located on two different Cp rings of ferrocene? Recently, Ikeda,<sup>13</sup> Ahn, Knochel, and our group<sup>14</sup> reported new 1,1'-disubstituted ferrocenyl ligands (Scheme 3). Using these ligands, good enantioselectivity was obtained for several asymmetric reactions. However, the introduction of planar chirality has rarely been reported for these 1,1'-disubsti-

Scheme 4

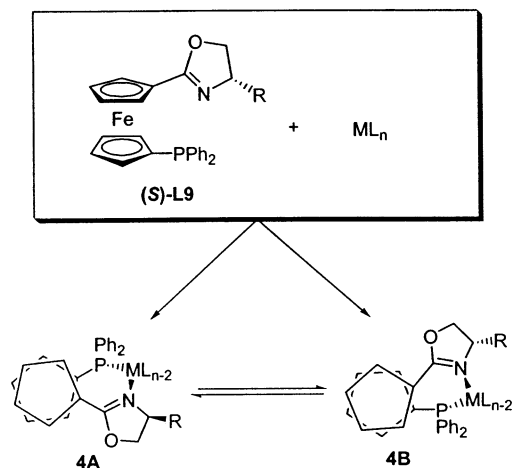

tuted ferrocene systems. Ligand **(S)-L9** has no planar chirality on the ferrocene backbone. However, coordination with a metal nevertheless leads to the formation of two rotamers, **4A** and **4B** (Scheme 4), due to rotation of the Cp rings.<sup>13,15</sup> This newly formed chirality is considered to be an axial chirality. Furthermore, after the introduction of planar chirality to ligand **(S)-L9** and coordination with a metal, three chiral elements (central, axial, and planar chirality) will exist in one catalyst. We were interested in exploring the enantioselectivity of this three-chiral-element catalyst in asymmetric reactions and the role of planar chirality in this particular 1,1'-system.

**(S)-L9** has been shown to be effective in the Pd-catalyzed allylic alkylation reaction. **(S,Sp)-L10** and **(S,Sp)-L11** were synthesized accordingly to introduce an additional planar chirality.<sup>14,15</sup> In the optimized reaction condition, **(S)-L9** gave 90.8% ee with an *S* configuration. When the third noncoordinating TMS group is introduced at the ortho position of the oxazoline ring, a dramatic change in enantio induction occurred.

The *Sp*-TMS group (**(S,Sp)-L10b**) changed the ee value to 69.7% with an *R* configuration. Such a great change is

strikingly different from that in the 1,2-system. When *Rp*-TMS (**(S,Rp)-L11b**) was used, the ee value climbed to 98.5% ee with an *S* configuration. In this 1,1'-system, planar chirality not only changed the ee value but also controlled the sense of the configuration. To clarify how the planar chirality governed the stereochemical outcome, X-ray crystallographic structures and <sup>1</sup>H NMR and <sup>31</sup>P NMR spectra of η<sup>3</sup>-diphenylallyl Pd complex of three 1,1'-P,N ferrocene ligands were analyzed with the aid of COSY and 2D NOESY experiments. All results supported the conclusion that planar chirality influences the stereochemical outcome by changing or even inverting the ratio of the two rotamers because of the steric interaction between the third introduced noncoordinating group and the coordination site. The steric demands of the third group were found to correlate directly with the enantioselectivity (Scheme 5, **(S,Sp)-10a-c**).

A simple rotamer representation is shown in Scheme 6, and **(S,Rp)-L11** occupied a sterically favorable disposition.

In fact, in the presence of the third group, a vigorous change in conformation occurred. Planar chirality played a very significant role in the allylic alkylation reaction in this 1,1'-system, although each of the other two chiral elements also has their own merits.<sup>15</sup>

The significance of planar chirality was also observed in the allylic amination reaction (Scheme 7) and Heck reaction (Scheme 8).<sup>14a</sup>

## Novel Chiral Ligands by Using Ferrocene as a Bulky Fragment

The asymmetric Pd-catalyzed allylic substitution reaction is a well-studied C–C and C–X bond-forming reaction, and great success has been achieved, particularly with a 1,3-diphenyl-substituted substrate. In contrast, little success has been achieved with an unsymmetrical substrate such as **9** or **10**, and a nonchiral linear product **I** was usually obtained (Scheme 9). Hayashi found that MeO-

Scheme 5

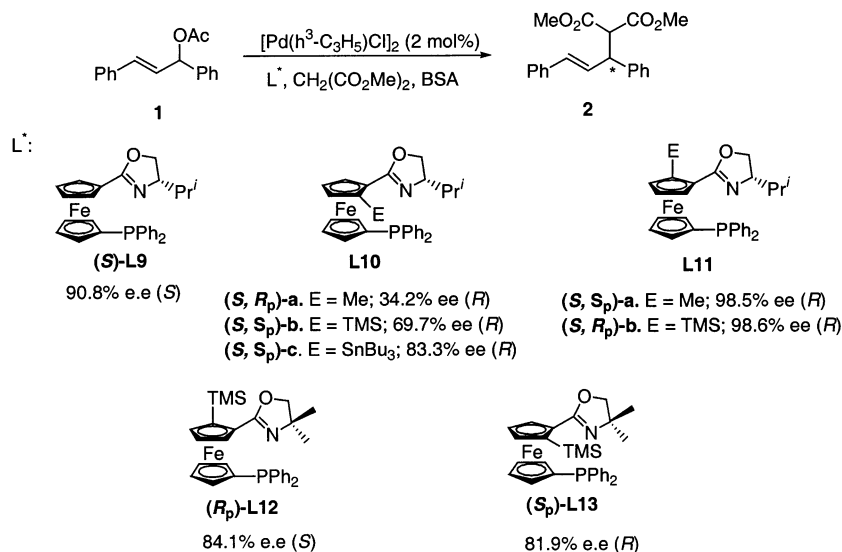

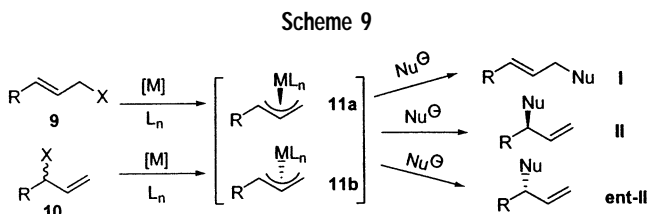
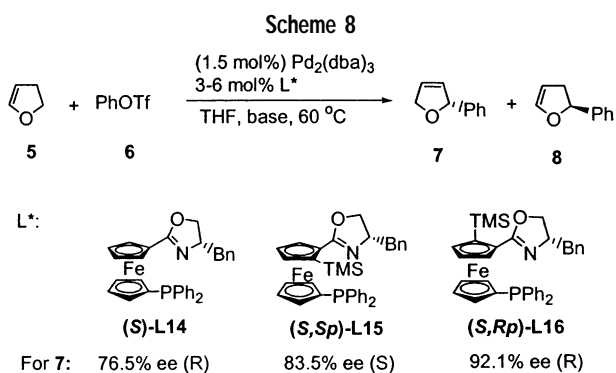
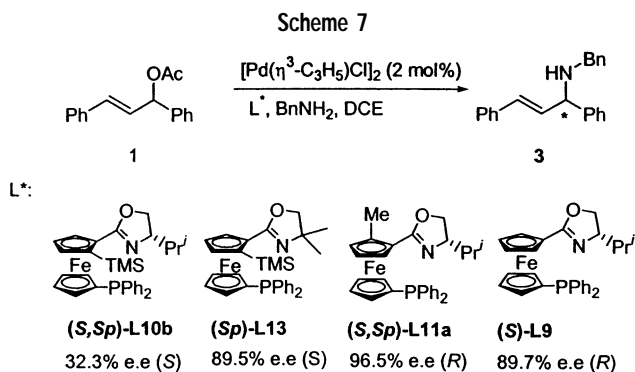
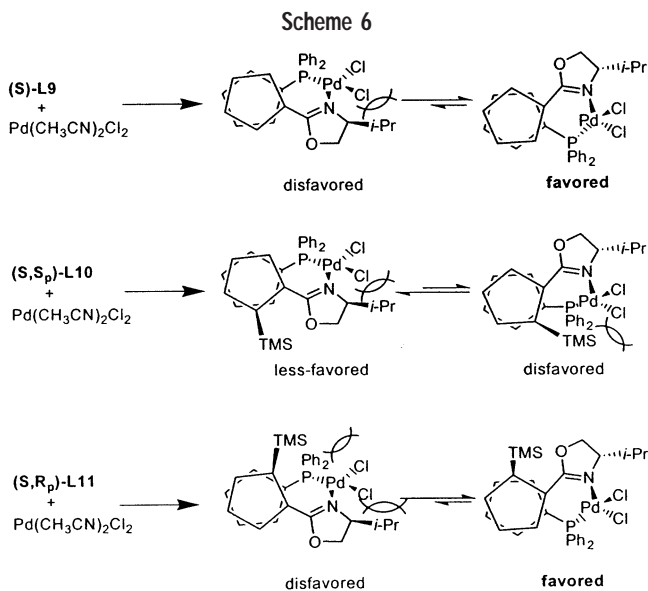

MOP gave good regio- and enantioselectivity for the branched product in the palladium-catalyzed alkylation of **10**, but a very low regioselectivity for substrate **9**.<sup>16</sup> Pfaltz developed phosphite-oxazoline ligands and used them to control the regio- and enantioselectivity for the chiral branched product in the palladium-catalyzed allylic alkylation of **9** or **10**.<sup>17</sup> High regio- and enantioselectivity were

achieved for 3-(1-naphthyl)-3-allylic acetate. However, only moderate to low regioselectivity was obtained for other aryl- and alkyl-substituted substrates.

For the regio- and enantioselective allylic amination reaction, pioneering work was performed by Hayashi and Ito with butenyl acetate as the only substrate.<sup>18</sup> On the basis of our previous results and those of others,<sup>16–18</sup> we can propose a working hypothesis. For intermediate **11a** or **11b**, there are four modes for the disposition of the  $\pi$ -allyl moiety to the catalyst (Scheme 10), where **P** and **N** stand for the donor atoms, and **P** > **N** for a trans effect; i.e., the C-atom trans to **P** is the point of attack for the nucleophile. Among these four modes, two lead to a linear product and the other two may lead to a branched product. On the basis of steric considerations, mode **D** is the most favorable. Thus, it is envisaged that two bulky groups are required for the donor atom **P**. Accordingly, **L17** is considered as our target ligand.<sup>19</sup> (Scheme 11)

We did not obtain the cyclic phosphonate **L17** as we had planned but, rather, obtained a phosphonamidate, and a free OH group on the BINOL moiety was retained. In this case, a new chiral center was formed on the P atom, and four diastereoisomers **L18**, **L19**, **L20**, and **L21** were obtained. The absolute configuration at the phosphorus atom was determined by X-ray diffraction analysis. The free OH functionality was retained, which is crucial in these reactions, and particularly in the amination reaction (vide infra). The phosphorus atom of this ligand was then loaded with two bulky moieties—ferrocene and BINOL skeletons. By screening the diastereoisomer and the group attached to the oxazoline ring, (S,S<sub>phos</sub>,R)-**L18d** was found to be the best ligand of choice. Under the optimized conditions using ligand (S,S<sub>phos</sub>,R)-**L18d** in the allylic alkylation reaction, a wide range of substrates was investigated. Representative results are summarized in Scheme 12. These results show that all of the reactions provided the branched products **12** with high regio- and enantioselectivity. Furthermore, this is good not only for substrates of type **9** but also for those of type **10**.

The above ferrocene-based P,N-ligands were also successfully applied to Pd-catalyzed allylic amination reactions, which are more challenging but very useful reactions for synthesizing allylic amines. Benzylamine was chosen as a nucleophile. First, **9a** or **10a** was used as the substrate. The reaction conditions were optimized by varying the ligand, solvent and temperature. Surprisingly, all of the (S,S<sub>phos</sub>,R)-**L18** and (S,R<sub>phos</sub>,S)-**L21** ligands that gave excellent results in the alkylation reaction provided linear products with a high ratio in the amination reaction.

Fortunately, high regio- and enantioselectivity for **10** were obtained by using (S,R<sub>phos</sub>,R)-**L19** and (S,S<sub>phos</sub>,S)-**L20** ligands; products with an opposite absolute configuration were obtained from **L19** and **L20**. With (S,R<sub>phos</sub>,R)-**L19c** as a ligand, the best reaction results were obtained at 0 °C in CH<sub>2</sub>Cl<sub>2</sub>, and a wide range of substrates were investigated (Scheme 13). All of the substrates gave excellent ee values and branched regio-selectivity. High regio- and relatively lower enantioselectivity were obtained

Scheme 10

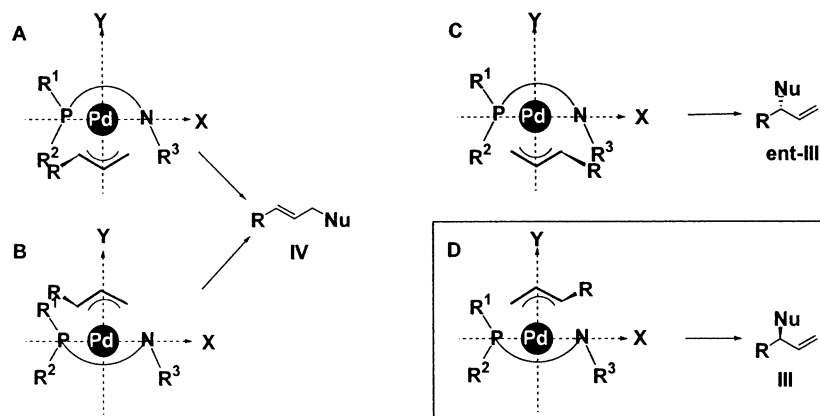

Scheme 11

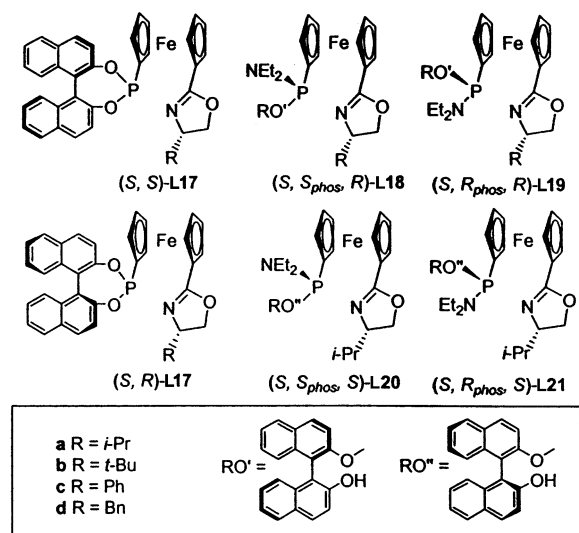

Scheme 12

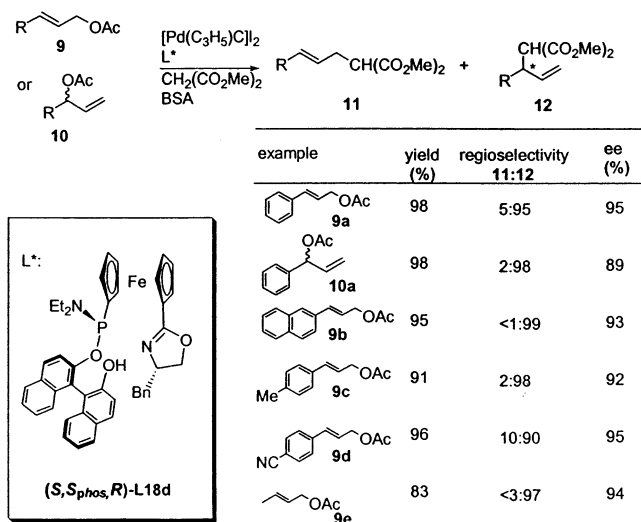

for **10e** with methyl as a substituent. However, only moderate regioselectivity was achieved with substrate **9**.

The favored ligands for these two reactions are entirely different. Ligands **(S, S<sub>phos</sub>, R)-L18** and **(S, R<sub>phos</sub>, S)-L21** gave better results in alkylation reactions, while **(S, R<sub>phos</sub>, R)-L19** and **(S, S<sub>phos</sub>, S)-L20** were better in amination reactions. The

Scheme 13

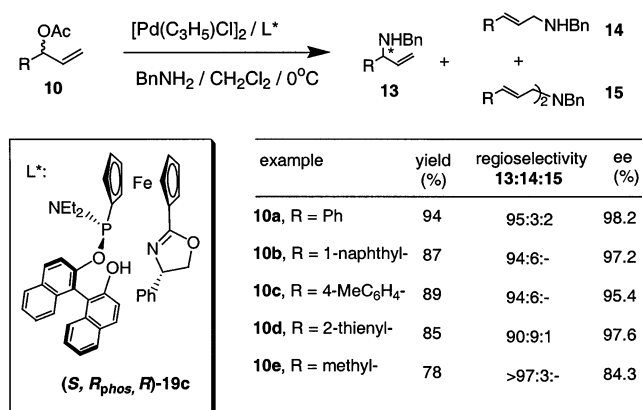

difference between these two sets of ligands in these reactions could possibly be explained as follows. In the amination reaction, a hydrogen bond might be formed between the free OH group of the ligand and the amine nucleophile. Thus, the nucleophile may attack in an intramolecular mode. The X-ray structures of these ligands showed two types of disposition of the OH group. For **L18** and **L21**, the OH group was directed outward from the metal center. For **L19** and **L20**, the OH group was directed inward toward the reaction center. For **L18** and **L21**, intramolecular attack by a nucleophile may favor the formation of a linear product, while branched products with a different configuration will be derived from **L19** and **L20**, which is consistent with the experimental results. To verify the above rationale, the free OH group of **L18a** and **L19a** was converted to a Me-ether, and the corresponding methylated ligands **(S, S<sub>phos</sub>, R)-L22** and **(S, R<sub>phos</sub>, R)-L23** were prepared. We expected that the regioselectivity with **L22** would be higher than that with **L18a**, and the regioselectivity using **L23** would be lower than that with **L19**. The results are consistent with our expectation. The regioselectivity with **L22** (63/31/6) for **9a** is higher than that with **L18a** (3/81/16), and that with **L23** (50/43/7) is lower than that with **L19a** (89/8/3). The reaction rate of the methylated ligand with **L22** and **L23** was much slower (72 h) than that with the unmethylated ligand (48 h) as a result of an intermolecular reaction instead of the original intramolecular reaction. Further-

Scheme 14

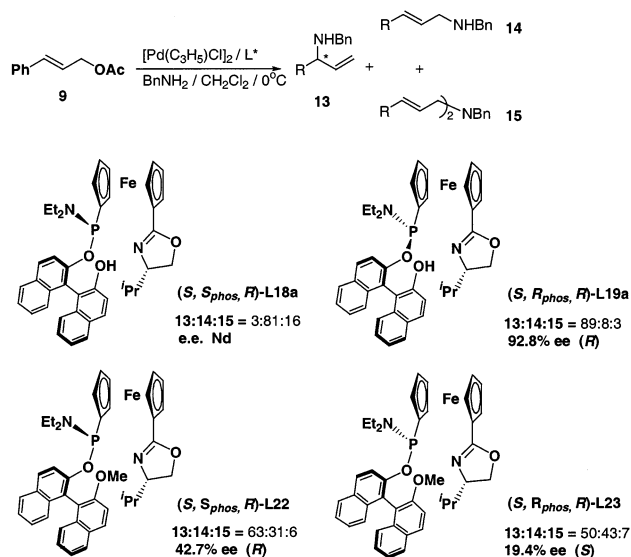

more,  $(\text{HCO})_2\text{N}^-$  was used instead of benzylamine, which is an amination reagent that cannot form a hydrogen bond. The results with this reagent are similar to those with the methyl-protected ligand. Therefore, it is clear that the hydroxyl group in the ligands plays a crucial role in the palladium-catalyzed allylic amination reaction.

The above results showed that the bulky ferrocene and bulky BINOL group, as well as the stereodisposition in the catalytic system, played an important role in the stereo-selection in the above reaction. Similarly, the use of a bulkier ferrocene skeleton instead of a benzene skeleton may offer good stereoselection in some other catalytic reaction. We have adopted this strategy to modify the well-known chiral pocket ligand devised by Trost.<sup>20</sup> In ferrocene-modified ligands **L24** and **L25**, there are two chiral centers and two planar chiralities, and the best results were obtained with a matched ligand (**R,R,Sp,Sp**)-**L25**, which has been successfully used in the asymmetric allylic alkylation reaction to construct a chiral quaternary center.<sup>21</sup> Interestingly, ligand **L25**·2H<sub>2</sub>O gave better results, although no explanation of the effect of two molecules of crystalline water is apparent at the moment. Examples are shown in Scheme 15.

In most cases, this ligand gave better results than the benzene analogue. Trost called his benzene chiral pocket a chiral fence, and the ferrocenyl chiral pocket described here may be considered a larger chiral fence.

The asymmetric allylic alkylation of iminoester has also been examined with this ligand,<sup>22</sup> and again better results were obtained with the simple allyl moiety.

## Novel Chiral Ligand in which the Electronic Nature of Phosphine Is Tunable based on the Derivatization of Ferrocene Compounds

The asymmetric intermolecular reaction between olefin and aryl sources has been developed mainly for cyclic substrates (predominantly dihydrofuran), which were first

Scheme 15

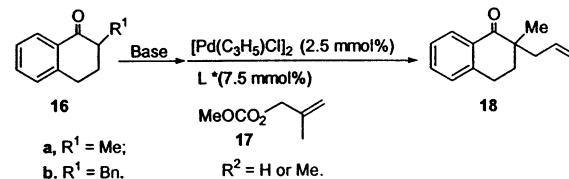

example	ligand	yield (%)	ee (%)
16a	L24	90	29
16a	L25	96	66
16a	L25 · 2H <sub>2</sub> O	96	95
16b	L25 · 2H <sub>2</sub> O	97	84

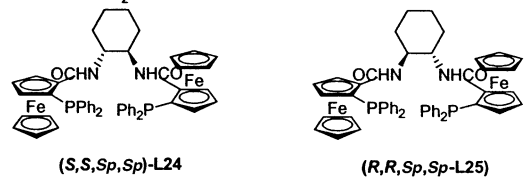

Scheme 16

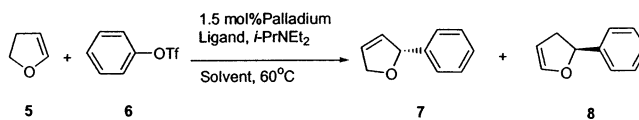

palladium source	solvent	conv. (%)	ratio 7:8	ee (%) for 7
Pd(dba) <sub>2</sub>	THF	98	28:72	97.1
Pd(OAc) <sub>2</sub>	THF	89	67:33	96.8
Pd(OAc) <sub>2</sub>	toluene	85	95:5	97.1
Pd(O <sub>2</sub> CCF <sub>3</sub> ) <sub>2</sub>	toluene	65	84:16	97.6

reported by Hayashi in 1991.<sup>23</sup> By using bidentate ligands, usually diphosphines or phosphine-oxazolines, high enantioselectivities have been achieved. When these ligands are used in the reaction of dihydrofuran **5** with phenyl triflate **6**, two different products **7** and **8** are obtained (Scheme 16), due to the possibility of double-bond isomerization. For diphosphine-type ligands, the double-bond migrated compound, 2-phenyl-2,3-dihydrofuran **8**, is obtained as a major product,<sup>23</sup> while for P,N-type ligands, the 2-phenyl-2,5-dihydrofuran **7** is formed predominantly.<sup>24</sup> However, the reason for this striking difference in regioselectivities and how to control the regioselectivity are not clear.

We designed and synthesized a series of new diphosphine-oxazoline ferrocenyl ligands, which belong to a system that is convenient for modification. We found that two different palladium precursors gave product with entirely different regioselectivities. With Pd(OAc)<sub>2</sub>, unsomerized **7** was the major product. In contrast, isomerized **8** was obtained as the major product when Pd(dba)<sub>2</sub> was used.<sup>25</sup>

Ligand **L26a** may follow a P,P-mode or a P,N-mode of coordination with a metal. As confirmed by X-ray and <sup>31</sup>P NMR results, ligand (**S,Sp**)-**L26a** functions as a diphosphine ligand in this reaction. It has been previously reported that diphosphine ligands with Pd(OAc)<sub>2</sub> usually

Scheme 17

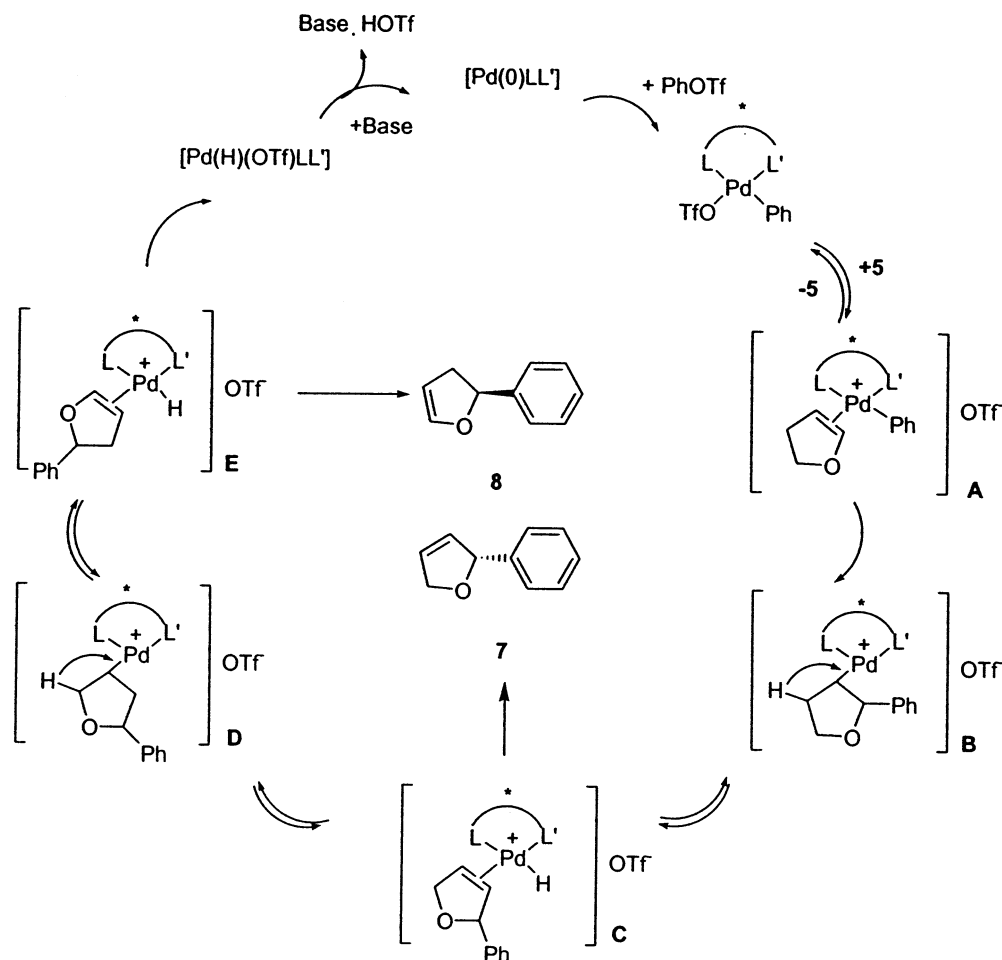

afford product **8** predominantly, however, when ligand (**S,Sp**)-**L26a** and Pd(OAc)<sub>2</sub> were used in this reaction, **7** was obtained as the major product (**7**:**8** = 95:5 in toluene, Scheme 16).

We sought to rationalize the different regioselectivities with Pd(OAc)<sub>2</sub> and Pd(dba)<sub>2</sub>. In the asymmetric intermolecular Heck reaction,<sup>24</sup> the hydride–olefin complex **C** is a point of demarcation between **7** and isomerized product **8**. Since the hydride–olefin complex **C** has a 16-electron square-planar structure, dissociation of the coordinated olefin should proceed via an associative mechanism involving an 18-electron transition state formed by nucleophilic attack of an incoming ligand at the palladium center. When Pd(OAc)<sub>2</sub> was used as a palladium source, the acetate anion in the reaction system should possess sufficient nucleophilicity toward the cationic palladium center in **C** to cause dissociation to give product **7**. However, when Pd(dba)<sub>2</sub> is used, no similar nucleophilic attack could occur, so that palladium would be reinserted in the olefin to give complex **D**. Subsequent β-hydride elimination therefore proceeded more readily to give **8** (Scheme 17).

If this explanation is valid, the electrophilicity of the cationic Pd atom of complex **C** might also influence the path toward **7** or **8**. Hence, a series of ligands bearing different electron-donating or electron-withdrawing groups

on phenyl rings of the phosphine were prepared and used in the Heck reaction. All of these ligands with Pd(OAc)<sub>2</sub> could catalyze the reaction in good conversions within 36 h, and isomer **7** was formed with high ee. The best regioselectivity of 99:1 for **7** and **8** was observed with ligand **L26b**, which has four strongly electron-withdrawing trifluoromethyl groups on the phenyl rings of the phosphine attached to the lower Cp ring, while a reversed ratio of 14:86 for the two isomers was found for ligand **L26c**, which contains two electron-donating methoxyl groups on the phenyl rings of phosphine. The diphosphine mode of coordination was supported by <sup>31</sup>P NMR spectroscopic studies in these two cases. This ratio was further changed to 8:92 when Pd(dba)<sub>2</sub> was used in conjunction with **L26c**. When ligand **L26b** coordinated with Pd to form hydride–olefin complex **C**, the electron-withdrawing trifluoromethyl groups could in principle lower the electron density on Pd<sup>+</sup>, thereby making it more vulnerable to being attacked by acetate anion, leading eventually to product **7**. However, because of the electron-donating effect of a methoxyl group, ligand **L26c** could enhance the electron density at the palladium center, leading to its reinsertion to the olefin to give isomer **8**.

These results suggested that the different electronic nature of ligating atoms greatly affected the regioselectivity. The literature has shown that different regioselectivity

Scheme 18

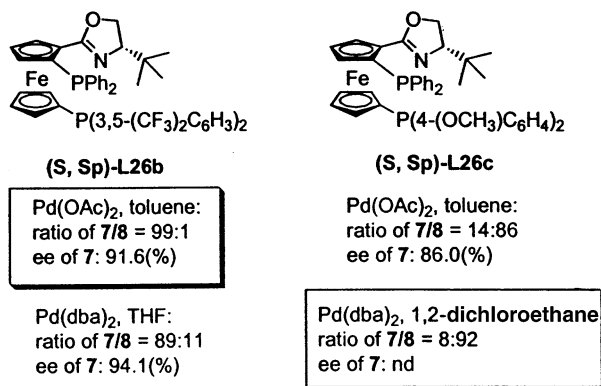

tivities are seen with P,P- and P,N-ligands. To explain this result, the atomic (Mulliken) charges of [PdH{(R)-BINAP}]<sup>+</sup> and [PdH{(S)-PHOX}]<sup>+</sup> were calculated at the PM3 level using Spartan 5.0, and we found that the charge on the palladium center of [PdH{(R)-BINAP}]<sup>+</sup> is -0.041975, while that of [PdH{(S)-PHOX}]<sup>+</sup> is +0.020161. The electron density on Pd<sup>+</sup> of hydride-olefin complex **C** with PHOX should be much lower than that with BINAP. Consequently, unisomerized isomer **7** was obtained as the main product with PHOX, while isomerized product **8** was obtained predominantly with BINAP due to the high electron density on the palladium center.

Tuning of the regioselectivity in the reaction of **5** with other aryl (naphthyl-, 4-methoxyphenyl-, and 4-nitrophenyl-) and cyclohexenyl triflates was also realized with ligands **L26a–c**, and similar trends in regioselectivity were also obtained. The easy derivatization of the ferrocene skeleton makes it possible to vary the electronic properties of the donor group to be possible.

The easy derivatization of the ferrocene skeleton also lets us study the sequence of the trans effects of C=N, S, and P.<sup>26</sup> Taking advantage of the established strategies,<sup>5</sup> we synthesized four *hetero*-bidentate ligands (**S,Rp**)-**L27–L30**, where the ligating groups have different dispositions on the same backbone. When these were used in the asymmetric allylic substitution reaction, ligands with different coordination atoms resulted in differences in the enantioselectivity and absolute configuration of the products. For ligand **L27** and **L28**, the disposition of the two groups was reversed, opposite asymmetric induction was observed. However, ligands **L28–L30** all gave products with an (*R*) configuration (Scheme 19).

Furthermore, these four ligands have the same backbone and the same chiralities (*S, Rp*), and, since the new C–Nu bond is formed outside of the coordination sphere of the metal center, regioselective attack is often achieved by electronic means.<sup>27</sup> The different configurations of the products should be due to the different trans effects of the ligating atoms in these ligands and/or different orientations of the allyl fragment in Pd- $\pi$ -allyl intermediates (vide infra) (Scheme 20).

On the basis of X-ray data and <sup>1</sup>H, <sup>13</sup>C, and <sup>31</sup>P as well as correlation studies for complexes **19–20**, the conformations of the reactive species were deduced, and they

Scheme 19

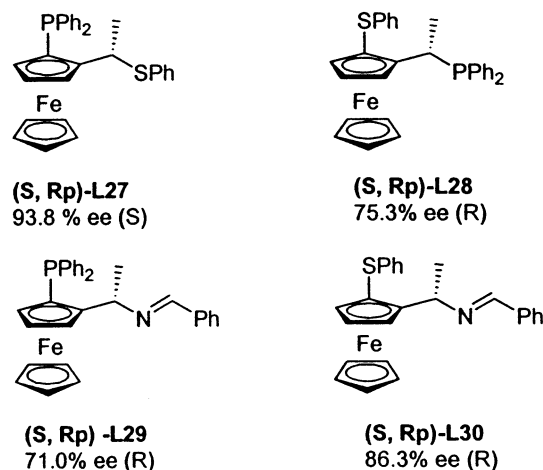

Scheme 20

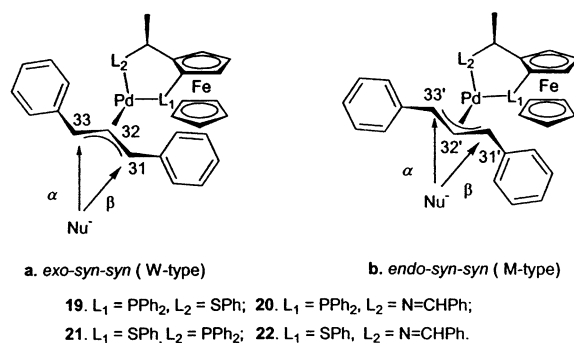

were all shown to be W type. In conjunction with the absolute configuration of the products, the trans effect of the donor atoms could be compared. In addition, the overall sequence of trans effects C=N > P > S could be obtained, which was supported by calculation of the atomic charge at the PM3 level.

## Conclusion

The role of the planar chirality of ferrocene ligands as well as the use of a bulky ferrocene fragment and tunable electronic properties of easily derivatized ferrocene ligands were discussed. Ferrocene offers several advantages as a scaffold for chiral ligands and may be beneficial for design of new chiral ligands for asymmetric catalysis. Although many important results have been obtained in this field, further investigations are needed and new applications remain to be explored.

*Financial support from the National Natural Science Foundation of China, Chinese Academy of Sciences, the Major Basic Research Development Program (Grant No. G2000077506), and the National Outstanding Youth Fund is acknowledged.*

## References

- (1) (a) Kealy, T. J.; Pauson, P. L. A new type of organo-iron compound. *Nature*, 1951, 168, 1039–1040. (b) Miller, S. A.; Tebboth, J. F.; Tremaine, J. F. Dicyclopentadienyliron. *J. Chem. Soc.* 1952, 632–635.
- (2) (a) Hayashi, T.; Togni, A., Eds. In *Ferrocenes*; VCH: Weinheim, Germany, 1995. (b) Togni, A.; Haltermann, R. L., Eds. In *Metallocenes*; VCH: Weinheim, Germany, 1998.



- (3) Review: (a) Borman, S. Researchers probe steps of taxol biosynthesis. *Chem. Eng. News* **1996**, *74*, 27–29. (b) Blaser, H. U.; Spindler, F. Enantioselective catalysis for agrochemicals. The case history of the DUAL-MAGNUM herbicide. *Chimia* **1997**, *51*, 297–299. (c) Imwinkelried, R. Catalytic asymmetric hydrogenation in the manufacture of d-biotin and dextromethorphan. *Chimia* **1997**, *51*, 300–302.
- (4) Elschenbroich, C.; Salzer, A. *Organometallics*. A Concise Introduction. VCH: Weinheim, 1989, 328.
- (5) Marquarding, D.; Klunsacek, H.; Gokel, G.; Hoffmann, P.; Ugi, I. Correlation of central and planar chirality in ferrocene derivatives. *J. Am. Chem. Soc.* **1970**, *92*, 5389–5393.
- (6) For ortho-metalation in other systems, see ref 15.
- (7) Hayashi, T.; Konishi, M.; Fukushima, M.; Mise, T.; Kagotani, M.; Tajika, M.; Kumada, M. Asymmetric synthesis catalyzed by chiral ferrocenylphosphine-transition metal complexes. 2. Nickel- and palladium-catalyzed asymmetric Grignard cross-coupling. *J. Am. Chem. Soc.* **1982**, *104*, 180–186.
- (8) Stangeland, E. L.; Sammakia, T. New chiral ligands for the asymmetric copper catalyzed conjugate addition of Grignard reagents to enones. *Tetrahedron* **1997**, *53*, 16503–16510.
- (9) (a) Wally, H.; Widhalm, M.; Weissensteiner, W.; Schlögl, K. A homoannularly bridged hydroxyamino ferrocene as an efficient catalyst for the enantioselective ethylation of aromatic and aliphatic aldehydes. *Tetrahedron: Asymmetry* **1993**, *4*, 285–288. (b) Du, X.-D.; Dai, L.-X.; Hou, X.-L.; Xia, L.-J.; Tang, M.-H. Highly efficient catalysts derived from planar chiral ferrocenes for asymmetric transfer hydrogenation of ketones. *Chin. J. Chem.* **1998**, *16*, 90–93.
- (10) (a) You, S.-L.; Zhou, Y.-G.; Hou, X.-L.; Dai, L.-X. Enantioselective palladium-catalyzed allylic substitution with chiral thioether derivatives of ferrocenyl-oxazoline and the role of planar chirality in this reaction. *Chem. Commun.* **1998**, *24*, 2765–2766. (b) You, S.-L.; Hou, X.-L.; Dai, L.-X. Synthesis of planar chiral selenide derivatives of ferrocenyl-oxazoline and their application in enantioselective palladium-catalyzed allylic substitution reaction. *Tetrahedron: Asymmetry* **2000**, *11*, 1495–1500.
- (11) You, S.-L.; Hou, X.-L.; Dai, L.-X.; Yu, Y.-H.; Xia, W. Role of planar chirality of S,N- and P,N-ferrocene ligands in palladium-catalyzed allylic substitutions. *J. Org. Chem.* **2002**, *67*, 4684–4695.
- (12) (a) Muniz, K.; Bolm, C. Configurational control in stereochemically pure ligands and metal complexes for asymmetric catalysis. *Chem. Eur. J.* **2000**, *6*, 2309–2316. (b) Bolm, C.; Muniz-Fernandez, K.; Seger, A.; Raabe, G.; Guenther, K. On the role of planar chirality in asymmetric catalysis: A study toward appropriate ferrocene ligands for diethylzinc additions. *J. Org. Chem.* **1998**, *63*, 7860–7867.
- (13) (a) Zhang, W.; Adachi, Y.; Hirao, T.; Ikeda, I. Highly diastereoselective ortho-lithiation of 1,1'-bis(oxazolonyl)ferrocene directed to C2-symmetric chiral ligands. *Tetrahedron: Asymmetry* **1996**, *7*, 451–460. (b) Zhang, W.; Yoneda, Y.; Kida, T.; Nakatsuji, Y.; Ikeda, I. Novel chiral P,N-ferrocene ligands in palladium-catalyzed asymmetric allylic alkylations. *Tetrahedron: Asymmetry* **1998**, *9*, 3371–3380.
- (14) (a) Deng, W.-P.; Hou, X.-L.; Dai, L.-X.; Dong, X.-W. Efficient planar chiral 2'-substituted 1,1'-P,N-ferrocene ligands for the asymmetric Heck reaction: control of enantioselectivity and configuration by planar chiral substituent. *Chem. Commun.* **2000**, 1483–1484. (b) Deng, W.-P.; Hou, X.-L.; Dai, L.-X.; Yu, Y.-H.; Xia, W. On the role of planar chirality: a tunable enantioselectivity in palladium-catalyzed allylic alkylation with planar chiral 1,1'-P, N-ferrocene ligands. *Chem. Commun.* **2000**, 285–286.
- (15) Deng, W.-P.; You, S.-L.; Hou, X.-L.; Dai, L.-X.; Yu, Y.-H.; Xia, W.; Sun, J. Importance of planar chirality in chiral catalysts with three chiral elements: the role of planar chirality in 2'-substituted 1,1'-P,N-ferrocene ligands on the enantioselectivity in Pd-catalyzed allylic substitution. *J. Am. Chem. Soc.* **2001**, *123*, 6508–6519.
- (16) Hayashi, T. Chiral monodentate phosphine ligand MOP for transition-metal-catalyzed asymmetric reactions. *Acc. Chem. Res.* **2000**, *33*, 354–362.
- (17) Helmchen, G.; Pfaltz, A. Phosphinooxazolines-A new class of versatile, modular P,N-ligands for asymmetric catalysis. *Acc. Chem. Res.* **2000**, *33*, 336–345.
- (18) Hayashi, T.; Kishi, K.; Yamamoto, A.; Ito, Y. Asymmetric allylic amination catalyzed by chiral ferrocenylphosphine palladium complexes. *Tetrahedron Lett.* **1990**, *31*, 1743–1746.
- (19) You, S.-L.; Zhu, X.-Z.; Luo, Y.-M.; Hou, X.-L.; Dai, L.-X. Highly regio- and enantioselective Pd-catalyzed allylic alkylation and amination of monosubstituted allylic acetates with novel ferrocene P,N-ligands. *J. Am. Chem. Soc.* **2001**, *123*, 7471–7472.
- (20) (a) Trost, B. M.; Calkins, T. L.; Bochet, C. G. A convergent synthesis of (+)-parviflorin, (+)-squamacin K, and (+)-5S-hydroxyparviflorin. *Angew. Chem., Int. Ed. Engl.* **1997**, *36*, 2632–2635. (b) Trost, B. M.; Ariza, X. Enantioselective allylations of azalactones with unsymmetrical acyclic allyl esters. *J. Am. Chem. Soc.* **1999**, *121*, 10727–10737.
- (21) You, S.-L.; Hou, X.-L.; Dai, L.-X.; Zhu, X.-Z. Highly efficient ligands for palladium-catalyzed asymmetric alkylation of ketone enolates. *Org. Lett.* **2001**, *3*, 149–151.
- (22) You, S.-L.; Hou, X.-L.; Dai, L.-X.; Cao, B.-X.; Sun, J. Novel bis-N-[2-(diphenylphosphino)ferrocenylcarbonyl]diaminocyclohexane ligands: application in asymmetric allylic alkylation of imino esters with simple allyl carbonate. *Chem. Commun.* **2000**, 1933–1934.
- (23) Ozawa, F.; Kubo, A.; Hayashi, T. Catalytic asymmetric arylation of 2,3-dihydrofuran with aryl triflates. *J. Am. Chem. Soc.* **1991**, *113*, 1417–19.
- (24) (a) Bolm, C.; Hildebrand, J. P.; Muniz, K.; Hermanns, N. Catalyzed asymmetric arylation reactions. *Angew. Chem., Int. Ed. Engl.* **2001**, *40*, 3284–3308. (b) Loiseleur, O.; Hayashi, M.; Keenan, M.; Schmees, N.; Pfaltz, A. Enantioselective Heck reactions using chiral P,N-ligands. *J. Organomet. Chem.* **1999**, *576*, 16–22.
- (25) Tu, T.; Deng, W.-P.; Hou, X.-L.; Dai, L.-X.; Dong, X.-C. The regioselectivity of asymmetric intermolecular Heck reaction with planar chiral diphosphine-oxazoline ferrocenyl ligands. *Chem. Eur. J.*, in press.
- (26) Tu, T.; Zhou, Y.-G.; Hou, X.-L.; Dai, L.-X.; Dong, X.-C.; Yu, Y.-H.; Sun, J. Trans effect of different coordinated atoms of planar chiral ferrocene ligands with the same backbone in Pd-catalyzed allylic substitutions. *Organometallics* **2003**, *22*, 1255–1265.
- (27) Enders, D.; Peters, R.; Lochtman, R.; Raabe, G.; Runsink, J.; Bats, J. W. Asymmetric synthesis of novel ferrocenyl ligands with planar and central chirality and their application to Pd-catalyzed allylic substitutions. *Eur. J. Org. Chem.* **2000**, 3399–3426.

AR020153M